



**Government of India
Central Water & Power Research Station
Khadakwasla, Pune – 411 024**

TENDER DOCUMENT

FOR

**Supply, Installation and Commissioning of Motorised Direct
Shear Apparatus for Soil samples**

Total Pages: 19

Phone: 24103220 / 24103267
Email: ee_civil@cwprs.gov.in



Fax : 020- 24381004
Website : www.cwprs.gov.in

**GOVERNMENT OF INDIA
MINISTRY OF WATER RESOURCES, RIVER DEVELOPMENT
& GANGA REJUVENATION
CENTRAL WATER & POWER RESEARCH STATION,
KHADAKWASLA, PUNE-24**

**THIS DOCUMENT FROM PAGE 2 ONWARDS SHOULD BE RETURNED IN
ORIGINAL DULY SIGNED**

BID DOCUMENT FOR

**Supply, Installation and Commissioning of Motorised Direct
Shear Apparatus for Soil samples**

INQUIRY NO. : 708/1/EE(C)/GEDSA/15
NAME OF BIDDER :
PHONE :
FAX :

LAST DATE FOR RECEIPT OF BIDS : 28.12.2015 UPTO 1430 HOURS

DATE OF OPENING OF BIDS : 28.12.2015 UPTO 1500 HOURS

THIS BID DOCUMENT CONTAINS THE FOLLOWING:

- TENDER NOTICE
- TERMS & CONDITIONS AND DOCUMENTS TO BE ENCLOSED ALONGWITH BIDS.
- MANNER OF SUBMISSION OF BIDS
- BILL OF QUANTITY
- TECHNICAL SPECIFICATIONS
- COMPLIANCE STATEMENT

THE BIDDER SHOULD READ ALL THE INSTRUCTIONS IN THE DOCUMENT THOROUGHLY BEFORE SUBMITTING THE BID AND ADHERE TO THE DATES GIVEN.

EXECUTIVE ENGINEER (CIVIL)



**Government of India
Central Water & Power Research Station
Khadakwasla, Pune – 411 024**

No.708/1/EE(C)/GE/DSA/2015/

Date :

TENDER NOTICE

Executive Engineer (Civil) CWPRS, Pune for and on behalf of the President of India, invites, sealed tenders from eligible suppliers for the supply of following stores:

Sr No	Item	Quantity	Earnest Money Deposit in Rupees
1.	Supply, Installation and Commissioning of Motorised, Microprocessor Based Direct Shear Apparatus with variable 12 speed adjustment, Data acquisition system and accessories along with Software for plotting and processing of results (specifications enclosed as Annexure I)	Three units	Rs. 28,000/- (Rupees Twenty Eight thousand only)

Tender forms could be obtained from the office between 0930 hrs and 1600 hrs upto 23.12.15 on payment of a non-refundable fee of Rs 500/- in cash or in the form of DD drawn in favour of Executive Engineer (Civil), CWPRS payable at Pune. Tender form can also be downloaded from CWPRS Website : www.cwprs.gov.in and should be submitted alongwith tender form fee of Rs 500/- in the form of DD drawn in favour of Executive Engineer (Civil), CWPRS payable at Pune. Bids received without exact EMD and Tender form fee will be summarily rejected.

Reputed Firms may send their lowest offers for the same in Sealed Envelopes superscribing Bid for the above mentioned item in person / by post so as to reach Executive Engineer (Civil), CWPRS, Pune 411 024 (India) on or before 28.12.15 upto 1430 hours, the Bids would be opened at 1500 hours on 28.12.15

Executive Engineer (Civil)

2.0 TERMS AND CONDITIONS

A) GENERAL

1. **ADHERENCE TO ALL THE TERMS AND CONDITIONS:** The bidder should adhere to all the terms and conditions. If there is any discrepancy in complying with any term and condition laid down, the bid is liable to be rejected and decision of the competent authority would be binding on the bidder.

2. **DUE DATE :** The bid received after the due date and time will be rejected.

3. **BID CLARIFICATION :** The bidder may obtain the required clarification if any, before presenting the bid. No clarification will be sought after opening of the tender.

4. **DOCUMENTS REQUIRED:** The documents of valid registration, contracts, authorization, dealership certificate for arranging supply of stores / instruments etc. should be supplied or it is likely that the bids would not be evaluated.

5. **UNDERTAKING BY THE OM:** A letter of undertaking from each of the Original Manufacturer (OM) for the machine / equipment supplier that in case the bidder authorized by them defaults in execution of this tender the OM(s) will take all steps for successful execution of the tender without any additional cost to the Govt.

6. **DETAILS OF TIE-UP WITH OM:** The bidder to give details of tie-up, in terms of supply, support, servicing and warranty etc. with OM(s). In case of a bidder quoting a product without proof of backing from OM their tender will be rejected without giving any notice.

7. **REJECTION OF BID :** The competent authority reserves the right to accept or reject any or all the bids without assigning any reasons therefore.

8. **LOWEST BIDDER (L1):** L1 vendor (bidder) shall be decided on the comprehensive total cost of all items in Technical specifications of material. Single option with most economical prices for the machine / equipment meeting specification ONLY will be accepted. Financial evaluation on common platform i.e. the cost incurred by CWPRS in getting the goods at their premises (concessional custom duty, transport and insurance) shall be included in arriving at the lowest bidder L1. Exchange rate on the date of opening of financial bid will be considered.

9. **BILL OF QUANTITY :** The quantities of procurement are stated in "Bill of Quantity".

10. **VALIDITY OF THE BID** : The bid for the work / supply shall remain open for a period of 180 days from the date of opening of bids. The Government shall, without prejudice to any other right or remedy, be at liberty to forfeit 50% of the earnest money if any bidder withdraws his bid before that date or makes any modification in the terms and conditions of the bid which are not acceptable to the department, and to forfeit whole of the earnest money if the bidder, whose bid is accepted, fails to commence the work / supply specified in the NIQ (along with changes in scope, if any) in prescribed time or abandons the work / supply before its completion.

11. **AMENDMENTS TO THE BIDS** : The amendments shall be notified in writing or by FAX to all prospective bidders on the address intimated at the time of purchase of the bid document from CWPRS and these amendments will be binding on them.

12. **MODIFICATION AND WITHDRAWAL OF BIDS:** - The bidder may modify or withdraw his bid after submission, provided that the written notice of the modification or withdrawal is received by the purchaser prior to the deadline prescribed for submission of bids. The bidder's modification or withdrawal notice shall be prepared, sealed, marked and dispatched as required in the case of bid submission.

13. **BID OPENING:** -

- a) CWPRS shall open bids in the presence of bidders or their authorized representatives who choose to attend, on due date. The bidder's representatives, who are present, shall sign an attendance register. Authority letter to this effect shall be submitted by the bidders before they are allowed to participate in bid opening.
- b) A maximum of two representatives of any bidder shall be authorized and permitted to attend the bid opening.
- c) The bidder's names, Bid prices, modifications, bid withdrawals and such other details as CWPRS, at its discretion, may consider appropriate will be announced at the time of opening.
- d) The date fixed for opening of bids, if subsequently declared as holiday by the CWPRS, the revised date of schedule will be notified. However, in absence of such notification, the bids will be opened on next working day, time and venue remaining unaltered.

14. **REPLIES TO QUERIES** : All the queries may please be replied point to point, so as avoid back reference.

15. **PLACEMENT OF ORDER** : CWPRS shall consider placement of orders for commercial supplies only on those eligible bidders whose offers have been found technically, commercially and financially acceptable and whose goods have been type approved / validated by CWPRS.

16. TERMINATION FOR DEFAULT:- CWPRS may, without prejudice to any other remedy for breach of contract, by written notice of default, sent to the supplier, terminate this contract in whole or in part :-

- a) If the supplier fails to deliver any or all of the goods within the time period(s) specified in the contract, or any extension thereof granted by CWPRS.
- b) If the supplier fails to perform any other obligation(s) under the Contract; and
- c) If the supplier, in either of the above circumstances, does not remedy his failure within a period of 15 days (or such longer period as CWPRS may authorise in writing) after receipt of the default notice from CWPRS.

17. ARBITRATION :-

In case of dispute the decision of the Director, CWPRS, Pune will be binding.

18. Resultant Contract will be interpreted under Indian laws.

19. OTHER TERMS AND CONDITIONS : Any other conditions not mentioned shall be dealt as per / GFR 2005 and CPWD Works Manual 2003.

B) TECHNICAL

1. TECHNICAL EVALUATION : Technical evaluation of the bid will be done strictly on the basis of compliance of quoted machine / equipment as mentioned in the technical specification enclosed with this bid document.

2. TESTING, COMMISSIONING AND TRAINING : Testing, commissioning and training, if any, should be undertaken by the supplier within thirty days from the receipt of material at CWPRS. It would be open to the competent authority to take serious action against the supplier, if timely action is not taken by the supplier.

3. TESTING OF MACHINE / EQUIPMENT: The machine / equipment shall be tested for important parameters and test results are to be submitted after commissioning.

4. CDs AND MANUALS : Supply of all original diskettes or CDs, all original manuals (in duplicate) and reference documentation should be done along with the machine / equipment.

5. WARRANTY : Warranty of TWO YEARS from the date of installation and commissioning / acceptance at CWPRS. Technical support and Customer support should be free during the warranty period.

The supplier shall warrant that the stores to be supplied shall be new and free from all defects and faults and materials used, workmanship and manufacture and shall be of the highest grade and consistent with the established and generally accepted standards for material of the type ordered and shall perform in full conformity with specifications and drawings. The supplier shall be responsible for any defect that may develop under the conditions provided by the contract and under proper use, arising from faulty material, design or workmanship such as corrosion of the equipment, inadequate quantity of material to meet equipment requirements, inadequate contact protection, deficiencies in circuit design and / or otherwise and shall remedy such defects at his own cost when called upon to do so by CWPRS who shall state in writing in what respect the stores are faulty. This warranty shall survive inspection or payment for / and acceptance of goods, but shall expire (except in respect of complaints notified prior to such date) twelve months after the stores have been taken over. The supplier, free of all charges at site including freight, insurance and other incidental charges, shall make replacement under warranty clause.

6. AFTER SALES SERVICE: The terms & conditions and scope of after sales services, maintenance, repairs, replacement, installation, commissioning, annual maintenance charges after warranty period etc. may be indicated.

7. SINGLE SUPPLIER: The total system satisfying above specifications from a single supplier will only be considered.

8. LIST OF USERS: The address of the users of the quoted machine / equipment in India may be given. Any relevant document which would support the credibility, competence of the bidder may be submitted.

Quotation should be submitted by Original Equipment Manufacturer (OEM) or its authorized dealer / supplier. Authorization letter in this regard must be submitted along with the bid document.

C) FINANCIAL

1. RATES TO BE QUOTED : All the rates may be quoted in Indian Rupees and foreign currency appropriately. The cost to be indicated for each item should be the landed cost inclusive of all taxes, levies, freight, etc. However rate amount of Excise Duty, Custom Duty, Sales tax or any other chargeable levies will be shown separately to make for the landed cost. The benefit of reduction in cost due to decrease in taxes etc. before the delivery will be passed on to the user. Vague terms such as taxes as applicable, subject to US \$ variation etc. shall not be acceptable.

2. DISCREPANCY IN RATES: The rates quoted shall be written in ink, both in figures and in words, If there is any discrepancy in the rates quoted in figures and words, the rates quoted in words would be considered.

3. **CUSTOM DUTY AND EXCISE DUTY EXEMPTION** : Excise duty exemption certificate and in case of imported items customs duty exemption certificate will be supplied by CWPRS, if applicable, under notification No 10/97 and 51/96 .

4. **DELIVERY OF MACHINE / EQUIPMENT**: The Machine / equipment is to be delivered, installed and commissioned at CWPRS, Pune. In the event of material / equipment(s) being supplied by road-transport under specific instructions to this effect, Octroi Exemption Certificate is not required as CWPRS is out of Pune Municipal Corporation limits.

5. **TERMS OF PAYMENT**: In case of indigenous supplies, 100% payment will be made through E-payment within 30 days after receipt of Machine / equipment and successful installations / commissioning as the case may be. No payment will be made for goods rejected at site on testing.

6. **SECURITY DEPOSIT**: Successful contractor / suppliers will have to deposit security deposit at the rate of 10% of the total Supply Order in the form of FDR, from Nationalised Bank drawn in favour of Executive Engineer (Civil), CWPRS, Pune-24 within 20 days of the receipt of acceptance of tender along with acknowledgement copy of supply order, failing which CWPRS will presume that the bidder is unable to accept the tender.

If the firm fails or neglects to observe or perform any of his obligations under the contract, it shall be lawful for CWPRS to forfeit, either in whole or in part, the security deposit furnished by the firm. Save as aforesaid, if the firm duly performs and completes the contract in all respects and presents absolute **“NO DEMAND CERTIFICATE”** in the prescribed form and returns in good conditions, the specifications, drawing and samples or other property belonging to CWPRS, CWPRS shall refund the security deposit to the firm after deducting all costs and other expenses that CWPRS may have incurred and all dues and other moneys including all losses and damages which CWPRS is entitled to recover from the firm.

7. **INCIDENTAL CHARGES** : All other incidental charges, if any may be indicated.

8. **DELIVERY PERIOD** : Delivery period shall be maximum 8 weeks and adhered to after receipt of supply order from CWPRS.

9. DELAYS IN THE SUPPLIERS'S PERFORMANCE :

a) Delivery and installation of the machine / equipment and its performance of the services shall be made by the Supplier in accordance with the time schedule specified by CWPRS in its purchase order. Also in case the supply is not completed in the stipulated delivery period, as indicated in the Purchase Order, CWPRS reserves the right either to short close / cancel this purchase order and / or recover liquidated damage charges. The cancellation / short closing of the

order shall be at the risk and responsibility of the supplier and CWPRS reserves the right to purchase balance unsupplied item at the risk and cost of the defaulting vendors.

b) Delay by the Supplier in the performance of its delivery obligations shall render the Supplier liable to any or all of the following sanctions: forfeiture of its performance security as per CPWD Works Manual 2003 and imposition of liquidated damages and / or termination of the contract for default as defined under clause 15 below.

c) If at any time during the performance of the contract, the supplier encounters condition impeding timely delivery of the machine / equipment and performance of service, the Supplier shall promptly notify to CWPRS in writing the fact of the delay, its likely duration and its cause(s). As soon as practicable after receipt of the supplier's notice, CWPRS shall evaluate the situation and may at its discretion extend the period for performance of the contract (by not more than 20 weeks)

10. FORCE MAJEURE : If, any time, during continuance of this contract, the performance in whole or in part by either party of any obligation under this contract is prevented or delayed by reasons of any war or hostility, acts of the public enemy, civil commotion, sabotage, fires, floods, explosions, epidemics, quarantine restrictions, strikes, lockouts or act of God (hereinafter referred to as events) provided notice of happenings of any such eventually is given by either party to the other within 21 days from the date of occurrence thereof, neither party shall by reason of such event be entitled to terminate this contract nor shall either party have any claim for damages against other in respect of such non-performance or delay in performance, and deliveries under the contract shall be resumed as soon as practicable after such an event come to an end or cease to exist, and the decision of CWPRS as to whether the deliveries have been so resumed or not shall be final and conclusive. Further that if the performance in whole of part of any obligation under this contract is prevented or delayed by reasons of any such event for period exceeding 60 days, either party may, at its option, terminate the contract.

Provided, also that if the contract is terminated under this clause, CWPRS shall be at liberty to take over from the Supplier at a price to be fixed by CWPRS, which shall be final, all unused, undamaged and acceptable materials, bought out components and stores in course of manufacture which may be in possession of the supplier at the time of such termination or such portion thereof as CWPRS may deem fit, except such materials, bought out components and stores as the supplier may with the concurrence of CWPRS elect to retain.

11. LIQUIDATED DAMAGES: The supplier shall carry out supply and installation of machine / equipment, associated peripherals according to the delivery and installation schedule stipulated in the Supply order. The time frame and the date

of delivery and installation mentioned in the delivery schedule shall be deemed to the essence of the Supply order and delivery must be completed not later than the date specified therein. In the event of failure of the supplier to deliver and install the said machine / equipment, supply of related licensed software, associated peripherals within the stipulated time, the Government of India shall at their option be entitled to recover from the Supplier as agreed liquidated damages, and not by way of penalty, a sum of **1% (One percent)** of the price of agreed total cost of supply of machine / equipment, associated peripherals as aforesaid for every week or part thereof, during which the delivery and installation of machine / equipment, associated peripherals may be in arrears. The suppliers liability for delay shall not exceed **10% (Ten per cent)** of the ordered price. Such damages shall be in full satisfaction of the Suppliers liability for the delay. If the delay is longer than **10 weeks** the Government of India shall, except as provided hereinafter, be entitled to cancel the order in full or in part at their sole discretion without any financial repercussions on Government of India.

12. RISK AND EXPENSE CLAUSE: In case any item is not supplied or rejected and the supplier is unable to provide replacement the total supply order will be deemed as rejected. In such an event CWPRS will be at liberty to procure the same from another source and in case the cost of the item is higher than the present ordered cost, the extra cost shall be recovered from the contractor through deductions from bills pending or by means of deposit of the same by the suppliers in the Government treasury.

13. CERTIFICATION AND SIGNING OF BID DOCUMENTS : All certificates and brochure submitted with the bid must bear the stamp of the company and these should be self certified by the authorized signatory on each page. CWPRS shall not take cognizance of documents that do not fulfill these conditions.

D) APPLICABLE FOR IMPORT CASES

1. EXEMPTION OF CUSTOM DUTY: CWPRS, Pune is a Central Government organization and is exempted from paying custom duty.

2. CONDITION FOR BIDDING FOR INDIAN AGENT AND PRINCIPAL: The Indian Agent on behalf of the foreign principal or the foreign principal directly could bid in a tender but not both. Further, in cases where an agent participates in a tender on behalf of one manufacturer, he will not be allowed to quote on behalf of another manufacturer along with the first manufacturer in a subsequent / parallel tender for the same item.

3. INDIAN REPRESENTATIVE : Representative in India with address and phone / telex / Fax / numbers, E-mail address and name of the contact person, and after sales service facilities available through that representative may be furnished. (In case of foreign supplier) Name & address of the Banker along with a relevant Bank codes may be furnished.

4. FREIGHT and INSURANCE: Freight and Insurance from Mumbai to Pune will be borne by Indian Representative, if the consignment is CIP/ CIF Mumbai.

5. CIP PRICES : In case of imported equipment quoted prices should be CIP Mumbai Airport and inclusive of all taxes / duties (custom, export) etc. After customs clearance, equipment/ machine should be delivered at CWPRS, Pune by the Indian representative. Cost for concessional customs duty / customs clearance, transportation and other incidental charges should be quoted along with bids or borne by the supplier. Necessary Customs exemption certificate would be provided by CWPRS, Pune.

6. SECURITY DEPOSIT : In case of foreign suppliers also 100% payment will be released in the form of Telegraphic transfer / Letter of Credit. As mentioned under C 11 above, the successful contractor / suppliers will have to deposit security deposit at the rate of 10% of the total Supply Order in the form of FDR, from Nationalized Bank drawn in favour of Executive Engineer (Civil), CWPRS, Pune-24 within 20 days of the receipt of acceptance of tender along with acknowledgement copy of supply order, failing which CWPRS will presume that the bidder is unable to accept the tender.

7. TERMS OF PAYMENT :

In case of imported equipment : 100% Payment will be made through Telegraphic Transfer / Letter of Credit if the supply is from outside India. The Telegraphic transfer / Letter of Credit will be operative on the production of under mentioned documents.

- a) Original Bill of Landing / Airway Bill.
- b) Commercially certified Invoices describing the stores delivered, quantity, unit rate and their total value in triplicate. The Invoice should indicate the discounts, if any,
- c) Packing List showing individual dimensions and weight of packages.
- d) Country of Origin Certificate (in duplicate.)
- e) Test Certificate
- f) Declaration by the Seller that the contents in each case are not less than those entered in the Invoice & the quality of the Stores are guaranteed as per the specifications asked for by CWPRS.
- g) Warrantee & Guarantee Certificates.
- h) Photo sanitary Certificate.

In case of Indian Manufacturer payment will be made within one month after successful installation and commissioning.

8. AGENCY COMMISSION : The Indian agent's commission is not payable by Central Government Department of Government of India i.e. CWPRS.

10. **DEMURRAGE CHARGES** : If a firm accepts an order and fails to execute the order, in full or part as per the Terms and Conditions stipulated therein, it will be open to the Director, CWPRS, Pune to recover liquidated damages from the firm at the rate of 1.0 % of value of the undelivered stores.

3.0 MANNER OF SUBMISSION OF BIDS

Bidders may please note that they have to submit their bids in two separate envelopes marked as **Envelope "A"** for technical bid and **Envelope "B"** for financial bid. The technical bid **should not** contain any financial information. Envelope should be sealed with lak etc.

Documents to be enclosed in Envelopes 'A' & 'B' are given below :

Documents to be enclosed along with Bids:-

TECHNICAL BID in Envelope 'A'

1. Bidder covering letter
2. Tender form fee of Rs 500/- drawn in the form of DD drawn in favour of Executive Engineer (Civil), CWPRS, Pune. **Bids received without exact Tender Form fee will be summarily rejected.**
3. **EARNEST MONEY DEPOSIT** : EMD of Rs 28,000/- (Rupees twenty Eight thousand Only) in Indian Rupees or equivalent foreign currency in case of foreign supply in the form of Demand Draft / Fixed Deposit Receipt on any Scheduled Bank drawn in favour of Executive Engineer (C), CWPRS, Khadakwasla, Pune - 411 024 should be enclosed. No interest will be paid on the amount of EMD. Exemption from payment of EMD will be granted wherever applicable on submission of necessary valid documents along with the tender. **Tender document without EMD & Tender Document Fee (Rs 500/-) will be rejected.**
4. Technical bid with printed literature on all the items quoted giving specifications, details & accessories clear mention should be made of deviation in specification between the printed literature & quoted item. Without this bid is liable to be rejected.
5. The technical bid should accompany **signed compliance statement** of the bidder, specifying compliance to each and every item of the specifications at Annexure I. The bid is liable to be **rejected** if compliance statement, duly signed is not supplied with the technical bid. The bidder should enclose the latest technical literature, detailing specifications, along with the technical bid. **It may please be noted that merely stating 'Yes' in compliance statement in any column will not be accepted. The actual numbers / description should be re-stated explicitly in all columns of the compliance statement.** Normally, the

9. **BANK CHARGES** : Bank charges on Letter of Credit / Sight Draft (both within India & outside India) shall be to suppliers account (In case of foreign procurement.)

same should also be seen in the technical literature of the items supplied with the bid. In case where the same is not available in the technical literature, the relevant pages of the manual should be submitted. The bids not satisfying with the above requirements are liable for rejection without any further correspondence with the bidder concerned.

6. A list of customers to whom similar supply in India has been made including the cost & the present status. All the quoted machine / equipment should be field proven and good international cliental of repute. Documentary evidence (list of users in India) in respect of the above should be submitted with the offer.

7. Dealership / Agency certificate from the manufacturer / Principals for supply through dealers / Agents. A letter of undertaking firm each of the original manufacturer (OM) for equipment that in case the bidder authorized by their defaults in execution of this tender the OM (C) will take all steps for successful execution of the tender without any additional cost to the Govt.

8. The detail of tie-up in terms of supply, support, servicing & warranty etc. with OM (C). Any other information that will establish credibility, reliability / capability of the suppliers to undertake the proposed supply.

9. Bid document from page 2 onwards in original duly signed by the bidder.

10. Copy of Agency agreement entered into with principals indicating the nature of after sales services of Indian Agents, precise relationship & mutual interest in the business (applicable for foreign cases only)

Financial bids of only those suppliers qualifying the Technical Bid will be considered for financial bid opening.

FINANCIAL BID in Envelope 'B'

1. Price schedule for machine / equipment to be supplied inclusive of cost of Installation, Commissioning and Testing charges (if any) and cost of Training.

2. Annual Report for the last 3 years.

The supplier should specifically note that he is not expected to put any conditions in his covering letter and further that if any such a condition is included in the covering letter, the bid may be rejected outright treating the same as a conditional bid.

There should be a separate marking on each of the two envelopes viz. "A-Technical Bid" and "B-Financial Bid". The two envelopes duly sealed should be put in one large envelope and the same should be submitted duly written at the top

The bid should be submitted to:

Executive Engineer (Civil) (Room No. 208)

Central Water and Power Research Station

P.O. Khadakwasla Research Station

Pune - 411024, India

Fax : 91-020-24381004

Phones : 91 - 020- 24103220 / 91 - 020- 24103267

Technical Specifications for Motorised, Microprocessor Based Direct Shear Apparatus

Purpose :

The Direct Shear Apparatus will be used for conducting direct shear tests on soil samples under drained and undrained conditions. The machine will comprise of a Loading frame to apply normal load on soil samples, shear box assembly to fit square samples of size 60 mm, complete with accessories and Electronic data acquisition system with software for processing and plotting of results. The detailed specifications of each of the component are given below.

A) SPECIFICATIONS :

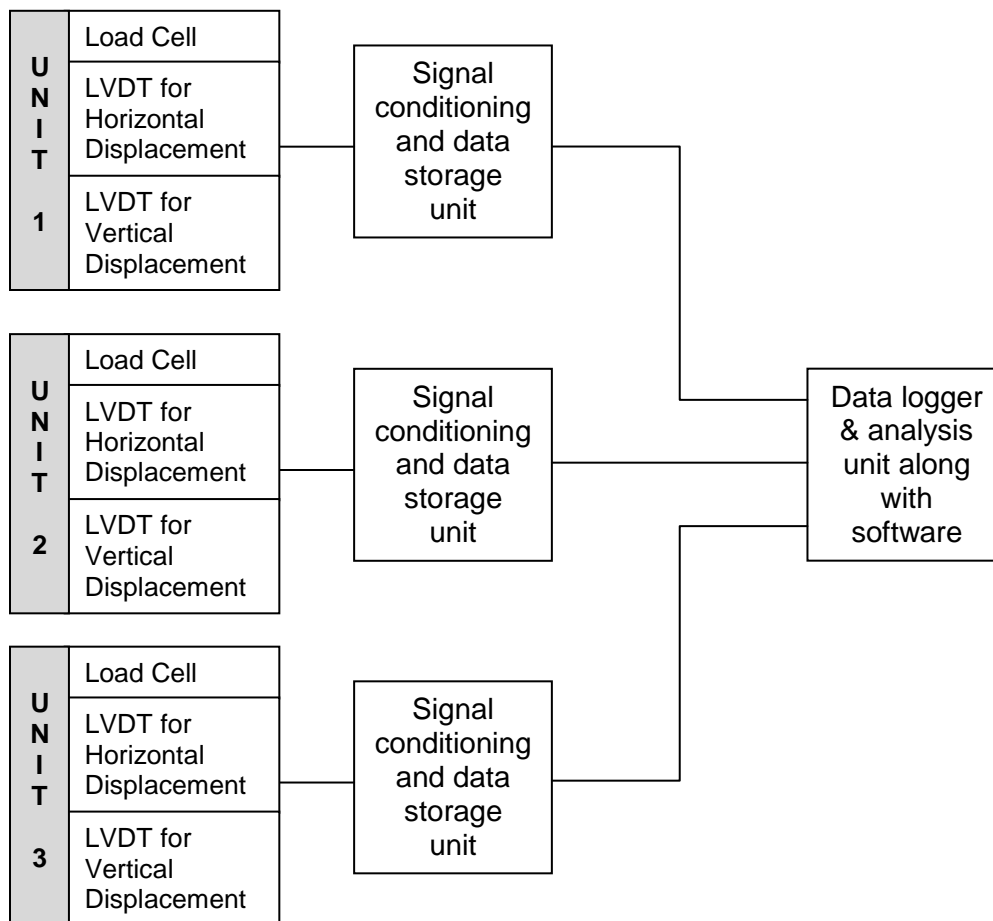

Fig. 1 Schematic Representation of Direct Shear Apparatus (3 Units) with Signal Conditioning and Data logger units

1	Direct Shear Apparatus	Conforming to Standard IS 2720 (Part XIII)
2	Load Frame Qty : 3 Units	<p>a) Loading unit with normal loading capacity of 8 kg/cm² on 60 mm square specimen Set of weights to apply normal stress up to 3 kg/cm² on the specimen through lever : 0.05 kg/cm² (4 nos.), 0.1 kg/cm² (1 no.), 0.2 kg/cm² (1 no.), 0.5 kg/cm² (3 nos.) and 1.0 kg/cm² (1 no.)</p> <p>b) Motor driven with adjustable 12 speed gear drive to provide 12 constant rates of strain i.e. 1.25, 0.625, 0.25, 0.125, 0.05, 0.025, 0.01, 0.005, 0.002, 0.001, 0.0004 and 0.0002 mm/min.</p>
3	Shear Box assembly Qty : 3 Sets	<p>a) A shear box housing of brass to house shear box assembly for sample size 60 mm X 60 mm X 25 mm</p> <p>b) Shear box with U bracket, guide pins, spacing screws, plain grid plates, perforated grid plates, loading pads (all made of brass), porous stones, specimen cutter etc.</p>
4	Measuring system for load, horizontal and vertical displacement Qty : 3 Sets	<p>a) Load : Load cells of minimum capacity 2000 N Resolution : 2 N or better</p> <p>b) Horizontal Displacement : LVDT, Range : 20 mm maximum. Resolution : 0.01 mm or better</p> <p>c) Vertical Displacement : LVDT, Range : 20 mm maximum. Resolution : 0.01 mm or better</p> <p>Calibration certificates for all sensors should be provided from accredited laboratory.</p>
5	Signal conditioning and data storage unit for each channel Qty : 3 Units	<p>a) 3 channel micro controller based with signal conditioning unit to receive output signal from sensors. Facility for storing of results and transferring to computer (Fig. 1).</p> <p>b) The units should be provided with LCD display for online monitoring of all three parameters.</p>
6	Data logger & analysis unit along with software	<p>a) Online Data transmission of digitally acquired signals for load, horizontal displacement and vertical displacement from Data storage units to data logger and analysis unit.</p> <p>b) Data logger and analysis unit consists of : Processor : I5 or better, RAM – Minimum 4 GB, HDD – Minimum 500 GB</p>

	Qty : 1 Unit	<p>LCD Display Unit : 17" with Minimum Resolution 1280 x 1024 with Keyboard, mouse, Graphic display card or inbuilt, with minimum 2GB RAM</p> <p>c) Facility for online monitoring, storing and processing of data through suitable Windows based software in data logger.</p> <p>d) The software must have following features:</p> <ul style="list-style-type: none"> • Calculation of area, volume, bulk density, moisture content of specimen • Online Plotting, display and storage of graphs : Shear stress vs strain, shear stress vs normal stress, horizontal displacement vs. vertical displacement
7	Eligibility criteria for bidders	The supplier shall have supplied at least 5 similar systems in the last three years. Complete user list shall be submitted along with the technical bid.

B) INSTALLATION, TESTING AND COMMISSIONING

1. The system should be installed and commissioned by the supplier at CWPRS, Pune.
2. Local service support must be provided for all supplied instruments and software through factory trained personnel at CWPRS.
3. The shortlisted supplier shall demonstrate the system within India upon request of the purchaser.

C) WARRANTY

Two year Comprehensive Warranty from the date of satisfactory installation and commissioning. The software should have Perpetual License and should work even after warranty period or without AMC / license renewal.

Quotation should be submitted by Original Equipment Manufacturer (OEM) or its authorized dealer / supplier. Authorization letter in this regard must be submitted along with the bid document.

Compliance Statement

A) SPECIFICATIONS :

Sr.No.	Description	Compliance, Deviations if any (Yes / No) with descriptive values
1	Direct Shear Apparatus	Conforming to Standard IS 2720 (Part XIII)
2	Load Frame Qty : 3 Units	a) Loading unit with normal loading capacity of 8 kg/cm ² on 60 mm square specimen Set of weights to apply normal stress up to 3 kg/cm ² on the specimen through lever : 0.05 kg/cm ² (4 nos.), 0.1 kg/cm ² (1 no.), 0.2 kg/cm ² (1 no.), 0.5 kg/cm ² (3 nos.) and 1.0 kg/cm ² (1 no.) b) Motor driven with adjustable 12 speed gear drive to provide 12 constant rates of strain i.e. 1.25, 0.625, 0.25, 0.125, 0.05, 0.025, 0.01, 0.005, 0.002, 0.001, 0.0004 and 0.0002 mm/min.
3	Shear Box assembly Qty : 3 Sets	a) A shear box housing of brass to house shear box assembly for sample size 60 mm X 60 mm X 25 mm b) Shear box with U bracket, guide pins, spacing screws, plain grid plates, perforated grid plates, loading pads (all made of brass), porous stones, specimen cutter etc.
4	Measuring system for load, horizontal and vertical displacement Qty : 3 Sets	a) Load : Load cells of minimum capacity 2000 N Resolution : 2 N or better b) Horizontal Displacement : LVDT, Range : 20 mm maximum. Resolution : 0.01 mm or better c) Vertical Displacement : LVDT, Range : 20 mm maximum. Resolution : 0.01 mm or better Calibration certificates for all sensors should be provided from accredited laboratory.
5	Signal conditioning and data storage unit for each channel Qty : 3 Units	a) 3 channel micro controller based with signal conditioning unit to receive output signal from sensors. Facility for storing of results and transferring to computer (Fig. 1). b) The units should be provided with LCD display for online monitoring of all three parameters.
6	Data logger & analysis unit along with software	a) Online Data transmission of digitally acquired signals for load, horizontal displacement and vertical displacement from Data storage units to data logger and analysis unit. b) Data logger and analysis unit consists of : Processor : I5 or better, RAM – Minimum 4 GB, HDD – Minimum 500 GB LCD Display Unit : 17" with Minimum Resolution 1280 x 1024 with Keyboard, mouse, Graphic display card or inbuilt, with minimum 2GB RAM c) Facility for online monitoring, storing and processing of

	Qty : 1 Unit	<p>data through suitable Windows based software in data logger.</p> <p>d) The software must have following features:</p> <ul style="list-style-type: none"> • Calculation of area, volume, bulk density, moisture content of specimen • Online Plotting, display and storage of graphs : Shear stress vs strain, shear stress vs normal stress, horizontal displacement vs. vertical displacement 	
7	Eligibility criteria for bidders	The supplier shall have supplied at least 5 similar systems in the last three years. Complete user list shall be submitted along with the technical bid.	

B) INSTALLATION, TESTING AND COMMISSIONING

	Compliance, Deviations if any (Yes / No) with descriptive values
<ol style="list-style-type: none"> 1. The system should be installed and commissioned by the supplier at CWPRS, Pune. 2. Local service support must be provided for all supplied instruments and software through factory trained personnel at CWPRS. 3. The shortlisted supplier shall demonstrate the system within India upon request of the purchaser. 	

C) WARRANTY

	Compliance, Deviations if any (Yes / No) with descriptive values
<ol style="list-style-type: none"> 1. Two year Comprehensive Warranty from the date of satisfactory installation and commissioning. The software should have Perpetual License and should work even after warranty period or without AMC / license renewal. 2. Quotation should be submitted by Original Equipment Manufacturer (OEM) or its authorized dealer / supplier. Authorization letter in this regard must be submitted along with the bid document. 	